

Ultimate Vent Block Dimensions

STATIONARY

MIDLAND TECHNOLOGIES

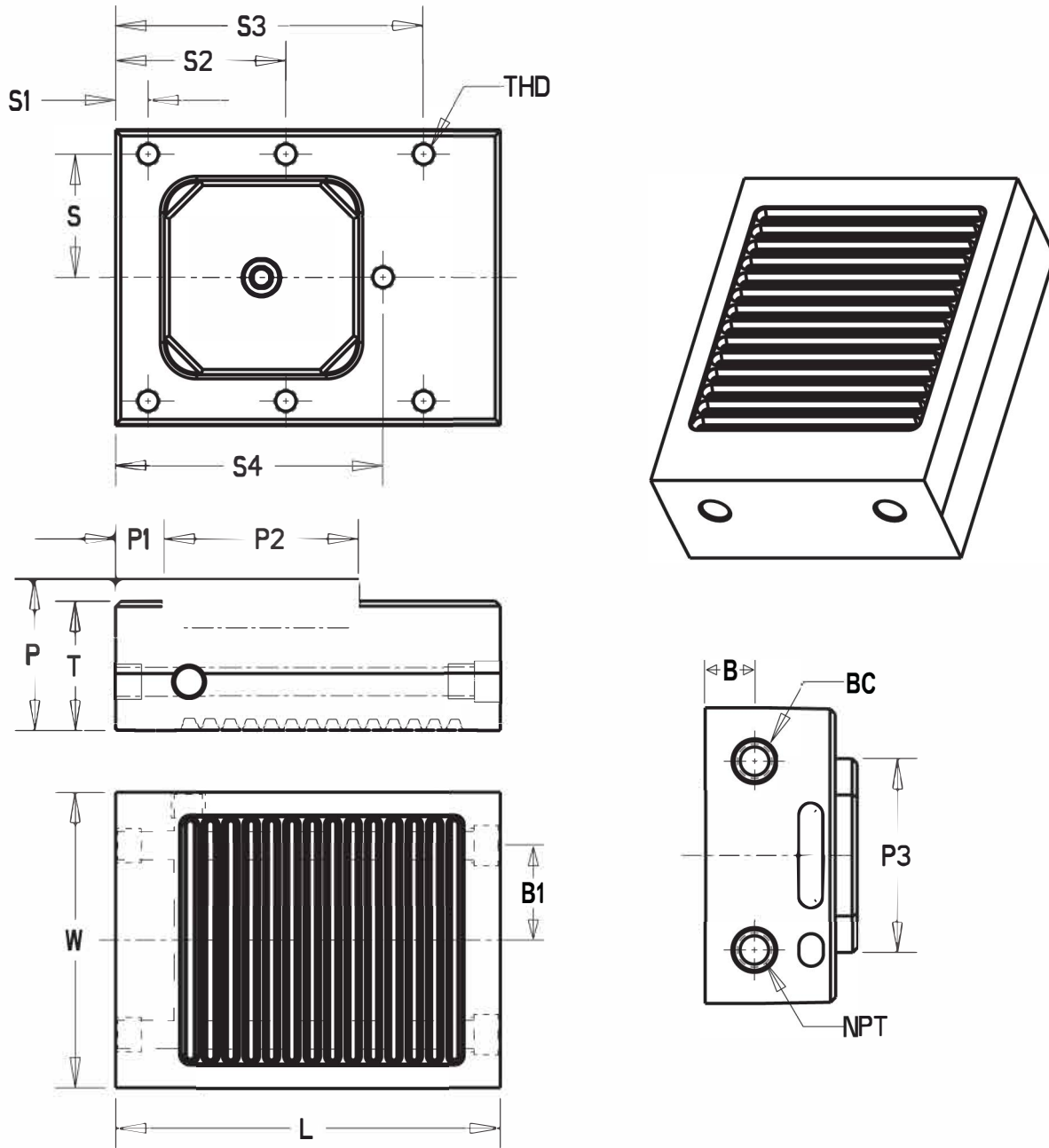

Model No.	W	L	T	P	P1	P2	P3	S	S1	S2	S3	S4	THD	NPT	B	B1	BC
	±.001	±.001	^{+.001} -.000	±.005	±.0005	±.001	±.005	±.02	±.02	±.02	±.02	±.02			±.02	±.02	SHCS Bolt Clearance
UVS-Mini	2.250	3.540	1.000	1.250	0.625	1.500	1.246	0.875	0.313	—	—	2.375	1/4-20	1/8	0.438	0.750	—
UVS-2500	2.500	5.940	2.000	2.340	0.750	3.000	1.496	1.000	0.500	2.250	4.000	—	1/4-20	1/4	1.125	0.625	3/8
UVS-4000	3.938	5.940	2.000	2.340	0.750	3.000	2.996	1.250	0.375	4.250	—	—	3/8-16	1/4	0.755	1.460	3/8
UVS-4500	4.566	5.940	2.000	2.340	0.750	3.000	2.996	1.905	0.500	3.500	—	—	3/8-16	1/4	0.755	1.460	3/8
UVS-5500	5.512	5.940	2.000	2.340	0.750	3.000	2.996	2.375	0.500	3.500	—	—	3/8-16	3/8	0.835	1.772	1/2
UVS-6500	6.500	5.940	2.000	2.340	0.750	3.000	2.996	2.375	0.500	3.500	—	—	3/8-16	3/8	0.835	1.772	1/2
UVS-8000	8.000	6.440	2.000	2.340	0.875	3.000	2.996	2.875	0.625	3.625	—	—	1/2-13	3/8	0.835	1.772	1/2

Patent # 7,134,637